

**Modular Cooking Range Line
 thermaline 80 - 1200 mm Ref-freezer
 Base with 2 drawers, 1 Side, H=550
 (R290)**

ITEM # _____

MODEL # _____

NAME # _____

SIS # _____

AIA # _____



588484 (MA6IDAKOBO) Ref-Freezer Base with 2 drawers, one-side operated - R290

Short Form Specification

Item No. _____

Refrigerated base with 2 drawers, able to operate both as refrigerator or freezer, with temperature range from -22°C to +8°C. Constructed according to 1.4301 (AISI 304) with anti-tilt runners accepting GN 2/1 containers. CFC and HCFC free, highly ecological refrigerant type: R290 (ecological gas in foam: cyclopentane). Hydrocarbon refrigerant gas R290 for the lowest environmental impact (GWP=3), to reduce green house and ozone depletion effects. Flat surface construction, easily cleanable. Large digital white-digit soft touch display. Handles ergonomically designed with embedded hygienic silicon "soft" grip enable easier handling and cleaning. Connectivity ready.
 IPX3 water resistance certification.
 Configuration: One-side operated freestanding base.

Main Features

- Two Drawer Refrigerated/Freezer Base with built-in compressor unit.
- Unit able to operate both as refrigerator or as freezer, with temperature range from -22°C to +8°C.
- Suitable for use in ambient temperatures of up to 40 °C.
- Designed for modular installation into the cooking block.
- All major components may be easily accessed from the front.
- Each drawer to accommodate one GN 2/1 container max 150 mm high.
- Magnetic snap-in drawer gaskets are removable for cleaning.
- Forced air circulation for rapid cooling and an even temperature distribution.
- Unit may be installed on castors.
- Unit constructed according to DIN 18860_2 with 70 mm recessed plinth.
- Perforated top surface and bottom plate for a better air circulation.
- Handles are ergonomically designed with silicon "soft" grip for easy handling and cleaning.

Construction

- Large digital white-digit display with soft touch buttons.
- Constructed in Stainless steel with Scotch Brite finish to meet the highest hygiene standards.
- Built-in compressor to suit operating conditions.
- IPX3 protected.

Sustainability

- CFC and HCFC free, highly ecological refrigerant type: R290 (ecological gas in foam: cyclopentane). Hydrocarbon refrigerant gas R290 for the lowest environmental impact (GWP=3), to reduce green house and ozone depletion effects.

Optional Accessories

- Ethernet connector for IR33 PNC 881299 □ (CAREL) Refrigerated Cabinets and Counters

APPROVAL: _____

Front

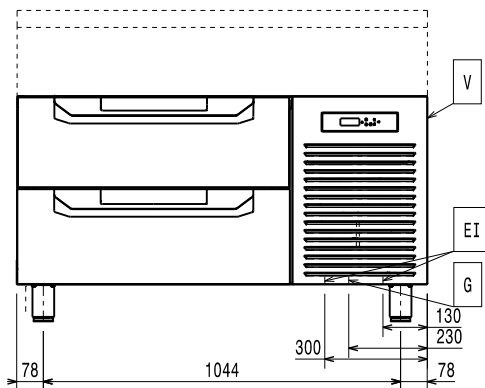

Side

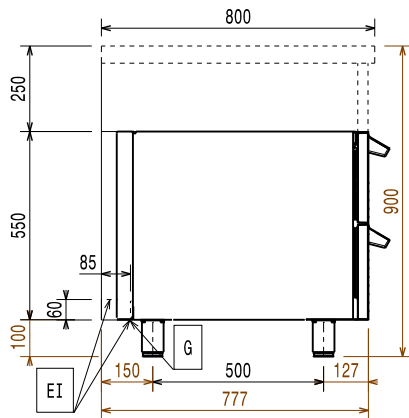

EI = Electrical inlet (power)

Top

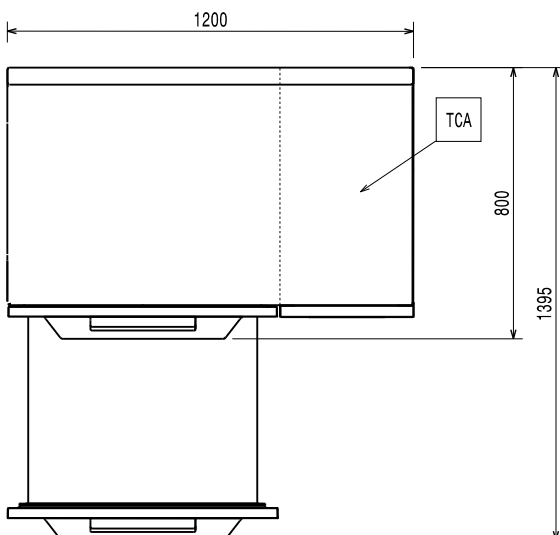

Electric

Supply voltage:	220-240 V/1N ph/50 Hz
Electrical power, max:	0.55 kW
Total Watts:	0.55 kW

Key Information:

External dimensions, Width:	1200 mm
External dimensions, Depth:	800 mm
External dimensions, Height:	550 mm
Net weight:	145 kg
N° of drawers:	2
Gross capacity:	

Refrigeration Data

Operating temperature min.:	8 °C
Operating temperature max.:	-22 °C
Compressor power:	
Defrost type:	Electric

Sustainability

Current consumption:	4.2 Amps
Refrigerant type:	R290
Refrigeration power:	0 W
Refrigerant weight (unit 1):	120 g